

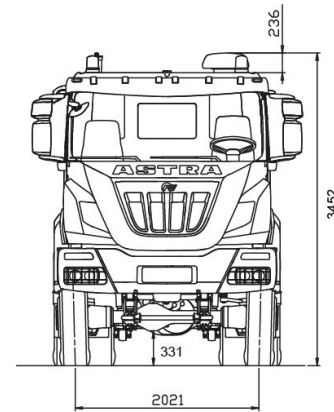

chassis 8x8  
**HD88.56**

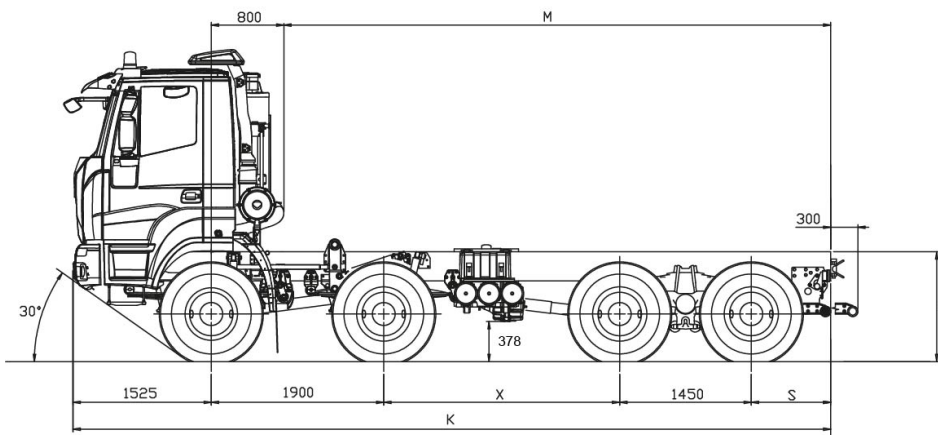

**DIMENSIONS (MM)**

X	K	M max(*)	S	H		TURNING DIAMETER (wall to wall)
				unloaded	loaded	
2850	8925	6600	1200	1205	1141	21400
3100	9175	6850	1200	1205	1141	22200
3350	9425	7100	1200	1205	1141	23000
3600	9975	7650	1500	1205	1141	23800
3960	10335	8020	1500	1205	1141	25400

(\*) M max.: indicative value to be confirmed by bodybuilder  
Tyres 13R22.5

**WEIGHTS (KG)**

X	Distribution net weight(*)			Max technical weight			
	Front axles	Rear axles	Net Weight	Front axles	Rear axles	Gross Vehicle Weight	Gross Combination Weight
2850	7525	4305	11830	16000 18000 (1)	32000	50000 (2)	104000 130000 (3)
3100	7520	4330	11850				
3350	7520	4350	11870				
3600	7510	4430	11940				
3960	7515	4450	11965				

(\*) Net weight including driver with tanks filled to at least 90%, equipped with standard equipment according to the manufacturer's specifications and, if fitted, the mass of the bodywork, spare wheels and tool box.  
 (1) With front axles reinforcing plate (opt 077), tyres on front axles 385/65R22.5 or 325/95R24 and reinforced springs (OPT).  
 (2) With front axles reinforcing plate (opt 077), tyres 325/95R24 or max speed limited to 70Km/h depending on tyre type and brand.  
 (3) For manual gearbox with additional parking brake air chambers. For automated gearbox check mission and configuration with Technical Dept.

**The data shown are indicative and non-binding. Payload and vehicle dimension data must always be verified during final testing. Do not use the drawing in the present sheet to design the equipment. Astra reserves the right to make any changes at any time and without notice.**



## ENGINES

**CURSOR 13** turbo intercooler diesel injection/cycle with electronic unit injection pumps. 6 in-line cylinders. Single block head, four valves per cylinder, light alloy pistons. Total displacement: 12.882 cm<sup>3</sup>. Bore for stroke: 135 x 150 mm. Water cooling. Dry air filter with safety cartridge. Vertical muffler. Emissions according to Euro 5 regulation norms SCR (Selective Catalytic Reduction) system composed of catalytic muffler, AdBlue-tank, injection and control system.

Max.power(EEC)	412 KW (560 HP) @ 1900 rpm
Max.torque(EEC)	2500 Nm (255 kgm) @ 1000 - 1690 rpm
Turbine	VGT(Variable Geometry Turbocharger)



## GEARBOX

Manual **ZF 16S2520TO** Ecosplit 4 technology gearbox with servoshift, 16 synchronised forward speeds + 2 reverse:

**On request:**

Automated TX 2610 TO, 12 forward speeds + 2 reverse

Automated **ASTRONIC ZF16AS2630 TO**

Automatic **ALLISON HD4700**, 7 speeds forward + 1 reverse



## CLUTCH

Single dry plate, diameter 17". Pull type engagement with diaphragm spring. Hydro-pneumatic power steering engagement control, with driven disk wear recovery slave cylinder.



## TRANSFER BOX

Mechanical with two ratios. Helical spur gears, mounted on three propeller shafts, engaged with each other. Lockable differential by pneumatic control from driver seat. Air-oil cooler. Transmission ratio 1:0,913 - 1:1,407. Front/rear torque distribution ratio 1:2,6.



## AXLES

### FRONT

1st and 2nd axle driving and steering, with double reduction: central by bevel gear, final by planetary gear in wheel hubs.

**On request:**

Cross-axle differential lock.

### REAR

Two driving axles in tandem, with double reduction: central with bevel gear, final by planetary gear in wheel hubs, interaxle and cross-axle differential lock. Tandem linked to the chassis by reaction rods with silentblocks.

**On request:** Rear-axle ratio 1:4,229; 1:5,009; 1:5,558; 1:6,095; 1:6,588.



## SUSPENSIONS

### FRONT

Parabolic springs, 3 leaves 26x90 mm, with hydraulic shock absorbers. Standard stabilizer bar on 1st axle.

**On request:**

Stabilizer bar on 2nd axle.

Reinforced parabolic springs, 4 leaves 26x90 mm (mandatory with 9t version).

### REAR

Parabolic springs, swivelling on central pin: 4 leaves 40x100 mm.

Standard stabilizer bar on 4th axle.

**On request:**

Stabilizer bar on 3rd axle.

Extra-reinforced conventional springs, 10 leaves 25x100 mm.



## CHASSIS

Special steel with high tensile strength limit, two flat and parallel side members (width 820 mm.), C section (320x90x10mm), cross members bolted to the frame. R.B.M. (Rail Bending Moment): 202.020 Nm (20.593 Kgm.). Steel front bumpers with headlamp protection grids, front maneuvering hook, rear underrun bar, rubber mud-guard 2nd axle, steel fuel tank capacity 300 litres.



## TYRES

**FRONT:** 13R22,5 156/150 G Single tubeless

**REAR:** 13R22,5 156/150 G Twin tubeless

Spare wheel on the chassis.

Other Possible combinations:

315/80 R22,5 156/150K

385/65 R22,5 160J (\*) + 315/80 R22,5 156/150K

325/95 R24 162/160K (\*)

(\*) Mandatory with 9 ton front axle load.

Other tyres available, subject to Astra technical office approval.



## BRAKES

Front and rear "duo-duplex" self-adjusting wedge type brakes with automatic play take-up. Total net braking surface 12.368 cm<sup>2</sup>. ABS + EBL.

**Service brake:** Pedal controlled air brake, acting on all wheels. Solo vehicles, two independent circuits, one for 1st and 2nd axle, one for 3rd and 4th axle. Towing vehicles, three independent circuits, one for 1st and 2nd axle, one for 3rd and 4th axle and another for the trailer.

**Emergency brake:** Incorporated in service brake.

**Parking brake:** Manual spring-type mechanical with pneumatic control acting on 3rd and 4th axle wheels.

**IVECO SUPER ENGINE BRAKE:** Braking power 463 kW (621 HP)

**On request:**

Hydraulic interarder.

OFF/ROAD button for excluding ABS for speed 15 kph.



## ELECTRICAL SYSTEM

Voltage: 24 V

Alternator generator 90 A - 28 V (2520 W).

Accumulators: 2 in series, 180 Ah.

Starter motor 24 V 5,5 kW.

Mechanically controlled electrical circuit breaker.



## CAB

Standard white short cab (AD) built in galvanized pressed steel with hydraulic tilting up to 60°. Cab suspension with 4 helicoidal springs with coaxial shock absorbers and integrated dampers, anti-roll bar and end-of-stroke pads. Tinted electric door windows. Internal panels completely washable and fireproof. Rapid pneumatic connection for cab cleaning. 4-speed ventilation and heating system with air recirculation system. Air suspended 3-way adjustable driver seat and mechanical passenger seat.