

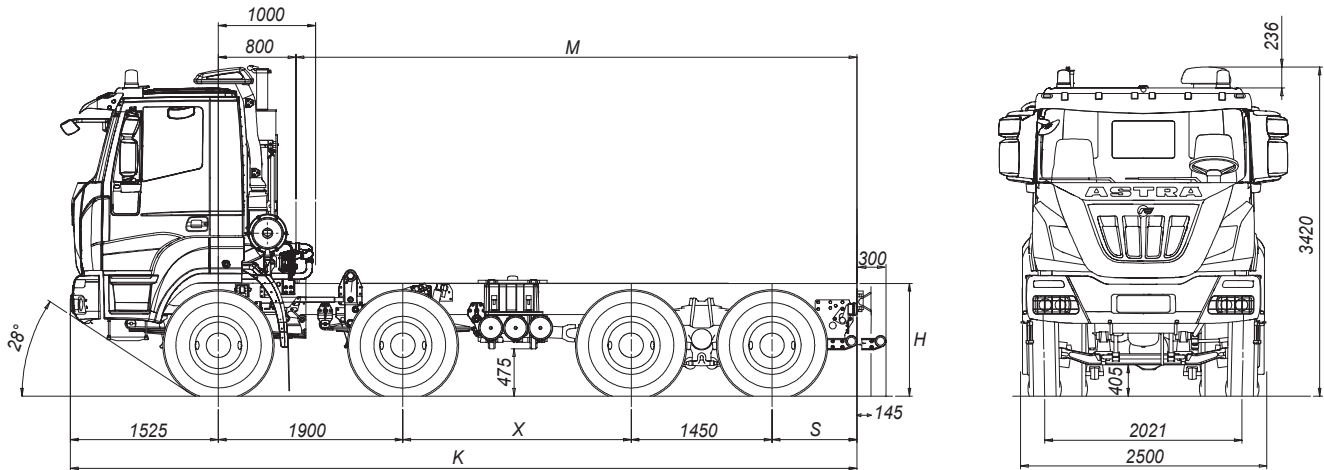

chassis-cab 8x6
86.44 / 86.48 / 86.54



chassis-cab 8x6



EURO 3



DIMENSIONS (mm)

X	K	M max (*)	S	H		TURNING DIAMETER (WALL TO WALL)
				unloaded	loaded	
2350	8425	6100	875-1200-1500	1249	1189	20530
2600	8675	6350	875-1200-1500	1249	1189	21300
2850	8925	6600	875-1200-1500	1249	1189	22070
3100	9175	6850	875-1200-1500	1249	1189	22850
3350	9425	7100	1200-1500	1249	1189	23630
3600	9975	7650	1500	1249	1189	24410
4100	10475	8150	1500	1249	1189	25990

(*) M max.: indicative value calculated in std configuration to be confirmed by bodybuilder.
Vertical dimensions with standard Tyres 13R22.5.



WEIGHTS (kg)

X	Distribution net weight (*)			Max technical weight			
	First axle	Rear axles	Net Weight	First axle	Rear axles	Gross Vehicle Weight	Gross Combination Weight
2350	6990	4205	11195	16000 18000 (1) (2)	32000 (2)	50000 (2)	56000 (3) 130000 (4)
2600	6985	4240	11225				
2850	6970	4270	11240				
3100	6975	4310	11285				
3350	6970	4335	11305				
3600	6955	4400	11355				
4100	6965	4445	11410				

(*) Weights are referred to standard configuration and include: chassis cab (or tractor), driver (75 kg), full fuel tank, tools kit and spare wheel (if present).

- (1) With tyres on front axles 385/65R22.5 or 325/95R24 and reinforced springs (OPT).
- (2) With tyres 325/95R24 or max speed limited to 70 Km/h depending on pneus type and brand.
- (3) This value is valid only for ZF Ecosplit 4 manual gearbox. The combination weight is 90.000 kg for ZF As-Tronic automated gearbox and 60.000 kg for Traxon automated gearbox.
- (4) For manual gearbox with additional parking brake air chambers. Exceptional charge < 5% of the time of use of the vehicle.

Characteristics and equipment are subject to changes without prior notice.
The data shown are indicative and non-binding.



ENGINES

CURSOR 13 turbo intercooler euro 3 diesel injection/cycle with electronic unit injection pumps. Single block head, four valves per cylinder, light alloy pistons. Total displacement: 12.882 cm³. Bore for stroke: 135x150 mm. 6 in-line cylinders. Water cooling. Dry air filter with safety cartridge. Vertical muffler.

	86.44	86.48	86.54
Model	Cursor 13		
Max power (EEC)	324 kW (440 HP)	353 kW (480 HP)	397 kW (540 HP)
Corresponding rpm	1900 rpm		
Max Torque (EEC)	2.100 Nm (214 kgm)	2.200 Nm (224 kgm)	2.350 Nm (240 kgm)
Turbine	VGT (Variable Geometry Turbine)		



GEARBOX

Manual **ZF Ecosplit** 4 technology gearbox with servoshift, 16 synchronised forward speeds + 2 reverse. First/last speed ratio: 13.80/0.84.

On request: Automated **ZF AS-Tronic**, 16 forward speeds + 2 reverse. First/last speed ratio: 14.12/0.83.

Automatic **ALLISON** transmission: only for wheelbase>4100mm. First/last speed ratio: 7.63/0.64.

Automated **ZF Traxon**, 12 forward speeds + 2 reverse. First/last speed ratio: 12.92/0.77.



CLUTCH

Single dry plate, diameter 17". Pull type engagement with diaphragm spring. Hydro- pneumatic power steering engagement control, with driven disc wear recovery slave cylinder.



TRANSFER BOX

Mechanical with two ratios. Helical spur gears, mounted on three shafts, engaged with each other. Lockable differential by pneumatic control from driver seat. Air- oil cooler. Transmission ratio 1:1 - 1:1,16. Front/rear torque distribution ratio 1:2,2.



AXLES

FRONT:

1st axle driving and steering, with double reduction: central by bevel gear, final by planetary gear in wheel hubs. 2nd axle in high tensile pressed steel, steering, not driving.

On request: Cross-axle differential lock.

Reinforced front axle: max technical weight 8 ton or 9 ton (with reinforced suspension). Available axle ratio: 5,01 - 5,47 -5,96 - 6,28.

REAR:

Two driving axles in tandem, with double reduction: central with bevel gear, final by planetary gear in wheel hubs, interaxle and cross-axle differential lock. Tandem linked to the chassis by reaction rods with silentblocks.

On request: Available rear-axle ratios: 1:3,793; 1:4,229 - 1:5,009 - 1:5,558 - 1:6,095 -1:6,588.



SUSPENSIONS

FRONT:

Parabolic springs, n° 3 leaves 26x90 mm, hydraulic shock absorbers. Standard stabilizer bar on 1st axle.

On request: Stabilizer bar on 2nd axle.

Reinforced parabolic springs, n° 4 leaves 26x90 mm (mandatory with 9t version).

REAR:

Parabolic springs, swiveling on central pin: n° 4 leaves 40x100mm, torque bars and stiffening brackets. Standard stabilizer bar on 4th axle.

On request: Stabilizer bar on 3rd axle.

Extra-reinforced conventional springs, n° 10 leaves 25x100 mm.



CHASSIS

Special steel with high tensile strength limit, two flat and parallel side members (width 820 mm.), C section (320x90x10mm), cross members bolted to the frame.

R.B.M. (Rail Bending Moment): 202.020 Nm (20.593 Kgm.). Steel front bumpers with headlamp protection grids, front maneuvering hook, rear underrun bar, rubber mud-guard 2nd axle, steel fuel tank capacity 300 litres.



TYRES

FRONT: 13R22,5 156/150 G Single tubeless.

REAR: 13R22,5 156/150 G Twin tubeless Spare wheel on the chassis.

Other possible combinations:

315/80R22.5 156/150K

385/65R22.5 160J (*) + 315/80R22.5 156/150K

325/95R24 162/160K (*)

(*) Mandatory with 9 ton front axle load.

Other tyres available, subject to the Astra technical office approval.



BRAKES

Front and rear "duo-duplex" self-adjusting wedge type brakes with automatic play take-up. Total net braking surface 12.058 cm². ABS + EBL system.

Service brake: Pedal controlled air brake, acting on all wheels.

Solo vehicles: two independent circuits, one for 1st and 2nd axle, one for 3rd and 4th axle.

Towing vehicles: three independent circuits, one for 1st and 2nd axle, one for 3rd and 4th axle and another for the trailer.

Emergency brake: Incorporated in service brake.

Parking brake: Mechanical spring-type with pneumatic control acting on 3rd and 4th axle wheels.

IVECO TURBO BRAKE engine brake.

On request: Hydraulic additional braking system on transmission (only for automated and automatic gearbox).



ELECTRICAL SYSTEM

Voltage: 24 V.

Alternator generator 90 A - 28 V (2520 W).

Accumulators: 2 in series, 180 Ah.

Starter motor 24 V 5,5 kW.

Mechanically controlled electrical circuit breaker.



CAB

White short cab built in galvanized pressed steel with hydraulic tilting up to 60°. Cab suspension with 4 helicoidal springs with coaxial shock absorbers and integrated dampers, anti-roll bar and end-of-stroke pads. Tinted electric door windows. Mechanical rear view mirrors, wide angle mirrors and front view mirror. Internal panels completely washable and fireproof. Compressed air quick coupling for cab cleaning. 4-speed ventilation and heating system with air recirculation system. Air suspended 3-way adjustable driver seat and mechanical passenger seat.