

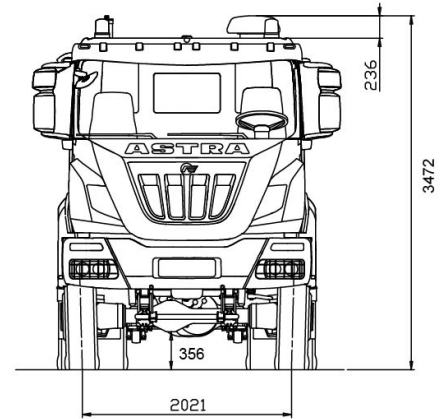

chassis 4x4
HD44.44

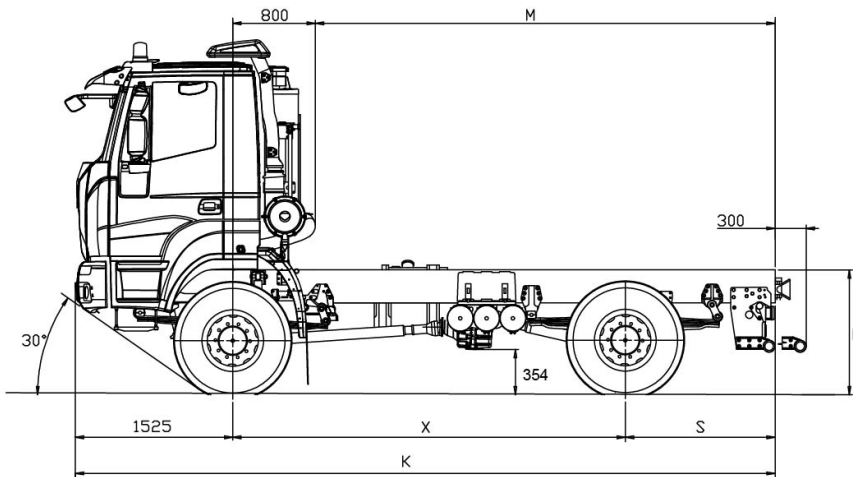

DIMENSIONS (MM)

| X | K | M max(*) | S | H | | TURNING DIAMETER (wall to wall) |
|------|------|----------|------|----------|--------|------------------------------------|
| | | | | unloaded | loaded | |
| 3800 | 6775 | 4450 | 1450 | 1203 | 1125 | 16000 |
| 4200 | 7575 | 5250 | 1850 | 1203 | 1125 | 17300 |
| 4600 | 8375 | 6050 | 2250 | 1203 | 1125 | 18600 |
| 5100 | 8875 | 6550 | 2250 | 1203 | 1125 | 20200 |

(*) M max.: indicative value to be confirmed by bodybuilder.
(Tyres 315/80R22.5).

WEIGHTS (KG)

| X | Distribution net weight(*) | | | Max technical weight | | | |
|------|----------------------------|------------|------------|----------------------|------------|----------------------|--------------------------|
| | First axle | Rear axles | Net Weight | First axle | Rear axles | Gross Vehicle Weight | Gross Combination Weight |
| 3800 | 5360 | 2540 | 7900 | 8000 9000 (l) | 13000 | 21000 | 55000 |
| 4200 | 5355 | 2590 | 7945 | | | | |
| 4600 | 5365 | 2660 | 8025 | | | | |
| 5100 | 5395 | 2655 | 8050 | | | | |

(*) Net weight including driver with tanks filled to at least 90%, equipped with standard equipment according to the manufacturer's specifications and, if fitted, the mass of the bodywork, spare wheels and tool box.

(l) With tyres on front axles 385/65R22.5 or 325/95R24 and reinforced springs (OPT).

The data shown are indicative and non-binding. Payload and vehicle dimension data must always be verified during final testing.

Do not use the drawing in the present sheet to design the equipment. Astra reserves the right to make any changes at any time and without notice.



ENGINES

CURSOR 13 turbo intercooler diesel injection/cycle with electronic unit injection pumps. 6 in-line cylinders. Single block head, four valves per cylinder, light alloy pistons. Total displacement: 12.882 cm³. Bore for stroke: 135 x 150 mm. Water cooling. Dry air filter with safety cartridge. Vertical muffler. Emissions according to Euro 5 regulation norms SCR (Selective Catalytic Reduction) system composed of catalytic muffler, AdBlue-tank, injection and control system.

| | |
|-----------------|-------------------------------------|
| Max.power(EEC) | 324 KW (440 HP) @ 1900 rpm |
| Max.torque(EEC) | 2200 Nm (224 kgm) @ 1000 - 1440 rpm |
| Turbine | VGT(Variable Geometry Turbocharger) |



GEARBOX

Manual **ZF 16S2520 TO** Ecosplit4 technology gearbox with servoshift, 16 synchronised forward speeds + 2 reverse:

On request:

Automated **ASTRONIC ZF 16AS2630TO**



CLUTCH

Single dry plate, diameter 17". Pull type engagement with diaphragm spring. Hydro-pneumatic power steering engagement control, with driven disk wear recovery slave cylinder.



TRANSFER BOX

Mechanical with two ratios. Helical spur gears, mounted on three propeller shafts, engaged with each other. Lockable differential by pneumatic control from driver seat. Transmission ratio: 1:1 - 1:1.6. Front/rear torque distribution ratio: 1:2.2.



AXLES

FRONT

1st axle driving and steering, with double reduction: central by bevel gear, final by planetary gear in wheel hubs.

On request:

Cross-axle differential lock.

REAR

Driving axle with double reduction: central with bevel gear, final by planetary gear in wheel hubs. Cross-axle differential lock.

On request: Rear-axle ratio 1:3.793; 1:4.229; 1:5.009; 1:5.558; 1:6.095; 1:6.588.



SUSPENSIONS

FRONT

1st axle, parabolic springs, 4 leaves 24x90 mm, with hydraulic shock absorbers. Standard stabilizer bar.

On request:

Reinforced parabolic springs, 5 leaves 24x90 mm (mandatory with 9t version).

REAR

Parabolic springs, 4 leaves 24x90 mm + 1 leaf 50x90 mm, with hydraulic shock absorbers. Standard stabilizer bar.



CHASSIS

Special steel with high tensile strength limit, two flat and parallel side members (width 820 mm.), C section (320x70x8 mm), cross members bolted to the frame. R.B.M. (Rail Bending Moment): 143.149 Nm (14.597 Kgm.). Steel front bumpers with headlamp protection grids, front manoeuvring hook, rear underrun bar, steel fuel tank capacity 300 litres.



TYRES

FRONT: 315/80R22.5 156/150 K Single tubeless

REAR: 315/80R22.5 156/150 K Twin tubeless

Spare wheel on the chassis.

Other Possible combinations:

13 R22.5 156/150K

385/65R22.5 160J (*) + 315/80R22.5 156/150K

325/95R24 162/160K (*)

395/85R20 168G (*)

(*) Mandatory with 9 ton front axle load.

Other tyres available, subject to the Astra technical office approval.



BRAKES

Front and rear drum brakes, Duo-Duplex with automatic slack adjuster.

ABS + EBL system.

Service brake: Pedal controlled air brake, acting on all wheels.

Solo vehicles: two independent circuits, one for 1st axle, one for 2nd axle.

Towing vehicles: three independent circuits, one for 1st axle, one for 2nd axle and another for the trailer.

Emergency brake: Integrated in service brake.

Parking brake: Mechanical spring-type with pneumatic control acting on 2nd axle wheels.

IVECO BRAKE TURBO engine brake: braking power 255 kW (347 HP).

On request: 1st axle immobiliser system.

OFF/ROAD button for excluding ABS for speed 15 kph.



ELECTRICAL SYSTEM

Voltage: 24 V

Alternator generator 90 A - 28 V (2520 W).

Accumulators: 2 in series, 180 Ah.

Starter motor 24 V 5.5 kW.

Mechanically controlled electrical circuit breaker.



CAB

Standard white short cab built in galvanized pressed steel with hydraulic tilting up to 60°. Cab suspension with 4 helicoidal springs with coaxial shock absorbers and integrated dampers, anti-roll bar and end-of-stroke pads. Tinted electric door windows. Mechanical rear view mirrors, wide angle mirrors and front view mirror. Internal panels completely washable and fireproof. Compressed air quick coupling for cab cleaning. 4-speed ventilation and heating system with air recirculation system. Air suspended 3-way adjustable driver seat and mechanical passenger seat.