

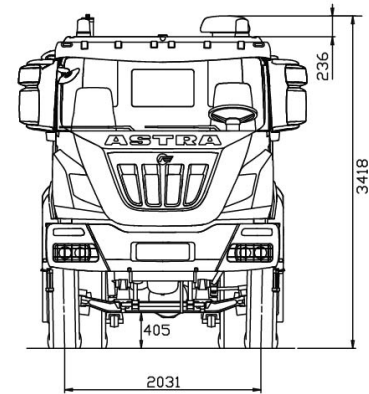
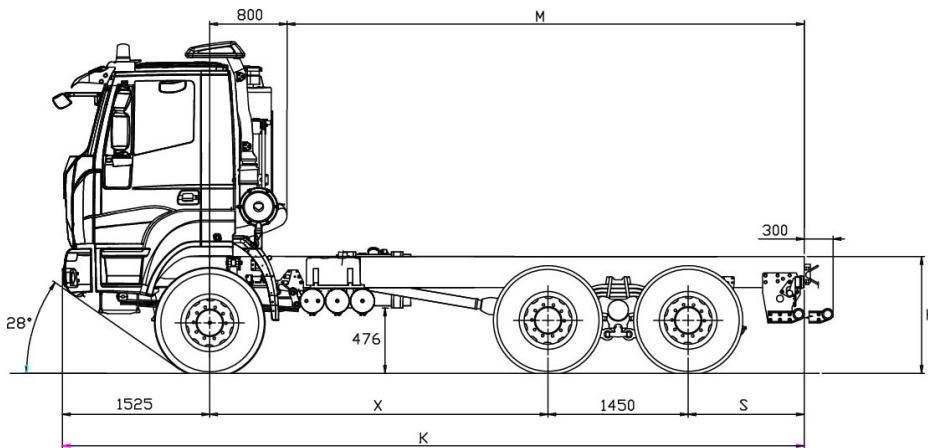

**chassis 6x4  
HD64.44**

**DIMENSIONS (MM)**

X	K	M max(*)	S	H		TURNING DIAMETER (wall to wall)
				unloaded	loaded	
3200	7375	5050	1200	1196	1129	15900
3500	7675	5350	1200	1196	1129	16800
3800	7975	5650	1200	1196	1129	17800
4100	8275	5950	1200	1196	1129	18700
4500	8675	6350	1200	1196	1129	20000

(\*) M max.: indicative value to be confirmed by bodybuilder  
(Tyres 13R22.5)

**WEIGHTS (KG)**

X	Distribution net weight(*)			Max technical weight			
	First axle	Rear axles	Net Weight	First axle	Rear axles	Gross Vehicle Weight	Gross Combination Weight
3200	4985	4760	9745	8000 9000 (1)	32000	40000 (2)	104000
3500	5020	4755	9775				
3800	5060	4765	9825				
4100	5085	4765	9850				
4500	5120	4765	9885				

(\*) Net weight including driver with tanks filled to at least 90%, equipped with standard equipment according to the manufacturer's specifications and, if fitted, the mass of the bodywork, spare wheels and tool box.

(1) With tyres on front axles 385/65R22.5 or 325/95R24 and reinforced springs (OPT).

(2) With tyres 325/95R24 or max speed limited to 70Km/h depending on pneus type and brand.

Higher speeds are allowed with load reductions subject to Astra technical office approval. Other tyres available, subject to Astra technical office approval.



## ENGINES

**CURSOR 13** turbo intercooler diesel injection/cycle with electronic unit injection pumps. 6 in-line cylinders. Single block head, four valves per cylinder, light alloy pistons. Total displacement: 12.882 cm<sup>3</sup>. Bore for stroke: 135 x 150 mm. Water cooling. Dry air filter with safety cartridge. Vertical muffler. Emissions according to  $\zeta$  5 regulation norms SCR (Selective Catalytic Reduction) system composed of catalytic muffler, AdBlue-tank, injection and control system.

Max.power(EEC) 324 KW (440 HP) @ 1900 rpm  
 Max.torque(EEC) 2200 Nm (224 kgm) @ 1000 - 1440 rpm  
 Turbine VGT(Variable Geometry Turbocharger)



## GEARBOX

Manual **ZF 16S2220TO** Ecosplit 4 technology gearbox with servoshift, 16 synchronised forward speeds + 2 reverse:

**On request:**

**ZF16S2320TD - ASTRONIC ZF16AS2630TO**

		Speed [kph] calculated at maximum power rpm																	
		Gears / Gear ratios																	
Gearbox model	Rear axle ratio	1st	2nd	3rd	4th	5th	6th	7th	8th	9th	10th	11th	12th	13th	14th	15th	16th	rev. 1st	rev. 2nd
<b>16AS 2630 TO</b>		14.12	11.68	9.54	7.89	6.52	5.39	4.57	3.78	3.09	2.56	2.09	1.73	1.43	1.18	1	.83	13.07	10.81
	<b>4.227</b>	6.51	7.87	9.64	11.66	14.11	17.06	20.12	24.33	29.76	35.92	44.00	53.16	64.31	77.94	91.97*	110.80*	7.04	8.51
<b>16S 2220 TO</b>		13.8	11.54	9.49	7.93	6.53	5.46	4.57	3.82	3.02	2.53	2.08	1.74	1.43	1.2	1.00	.84	12.92	10.8
	<b>4.227</b>	6.66	7.97	9.69	11.60	14.08	16.84	20.12	24.07	30.45	36.35	44.21	52.85	64.31	76.64	91.97*	109.48*	7.12	8.52

(\*) Max limited speed 90 km/h. Other speeds available, subject to the Astra technical office approval.



## CLUTCH

Single dry plate, diameter 17". Pull type engagement with diaphragm spring. Hydro-pneumatic power steering engagement control, with driven disk wear recovery slave cylinder.

**On request:** Ceramic clutch 17".



## AXLES

### FRONT

Steering, hot moulding in high tensile steel. Wheel stud protection.

### REAR

Double drive axles. Double reduction: crown wheel and pinion centrally and epicyclic group in wheel hubs. 2nd axle with torque distributor to the two rear axles. Lockable differentials by pneumatic control from driver's seat. Tandem assembled to the chassis by reaction rods with silentblock.

**On request:**

Rear-axle ratio 1:3.793 - 1:4,229 - 1:5,009 - 1:5,558 - 1:6,095 - 1:6,588.



## SUSPENSIONS

### FRONT

1st axle, parabolic springs, n° 4 leaves 24x90 mm, with hydraulic shock absorbers and standard stabilizer bar.

**On request:**

Reinforced parabolic springs, n° 5 leaves 24x90 mm.

### REAR

Parabolic springs, swivelling on central pin: n° 4 leaves 40x100 mm.

**On request:**

Stabilizer bar on 2nd axle.

Stabilizer bar on 3rd axle.

Extra-reinforced conventional springs, n° 10 leaves 25x100 mm.



## CHASSIS

Special steel with high elasticity limit, two flat and parallel side members (width 820 mm.), C section (320x90x10mm), cross members riveted to the frame. R.B.M. (Rail Bending Moment): 202.020 Nm (20.593 Kgm.). Steel front bumpers with headlamp protection grids, front manoeuvring hook, rear underrun bar, steel fuel tank capacity 300 litres.



## TYRES

**FRONT:** 13R22,5 156/150 G Single tubeless

**REAR:** 13R22,5 156/150 G Twin tubeless

Spare wheel on the chassis.

Other Possible combinations:

315/80R22.5 156/150K

385/65R22.5 160J (\*) + 315/80R22.5 156/150K

325/95R24 162/160K (\*)

(\*) Mandatory with 9 ton front axle load

Other tyres available, subject to the Astra technical office approval.

Characteristics and equipment are subject to changes without prior notice  
 Technical data and general specifications - validity to be checked according to each individual configuration



## BRAKES

Front and rear "duo-duplex" self-adjusting wedge type brakes with automatic play take-up. Total net braking surface 9.276 cm<sup>2</sup>. ABS.

**Service brake:** Pedal controlled air brake, acting on all wheels. Solo vehicles, two independent circuits, one for 1st axle, one for 2nd and 3rd axle; Towing vehicles, three independent circuits, one for 1st axle, one for 2nd and 3rd axle and another for the trailer.

**Emergency brake:** Incorporated in service brake.

**Parking brake:** Manual spring-type mechanical with pneumatic control acting on 2nd and 3rd axle wheels.

**IVECO BRAKE TURBO** engine brake: braking power 255 kW (347 cv)

**On request:**

1st axle immobiliser system.

OFF/ROAD button for excluding ABS for speed 15 kph.



## STEERING

ZF 8098 quadrilateral power steering on front axle wheels with variable ratio 1:22.2/1:26.2 with auxiliary cylinder. Circuit with main hydraulic pump on engine and emergency pump on gearbox. Steering rods with self-lubricating joints. Height and inclination pneumatic adjustable steering column.



## ELECTRICAL SYSTEM

Voltage: 24 V

Alternator generator 90 A - 28 V (2520 W).

Accumulators: 2 in series, 180 Ah.

Starter motor 24 V 5,5 kW.

Mechanically controlled electrical circuit breaker.



## CAB

White cab built in galvanized pressed steel with hydraulic tilting up to 60°. Cab suspension with 4 helicoidal springs with coaxial shock absorbers and integrated dampers, anti-roll bar and end-of-stroke pads. Tinted electric door windows. Internal panels completely washable and fireproof. Compressed air quick coupling for cab cleaning. 4-speed ventilation and heating system with air recirculation system. Air suspended 3-way adjustable driver seat with seat belts. Mechanical passenger seat with seat belts.