

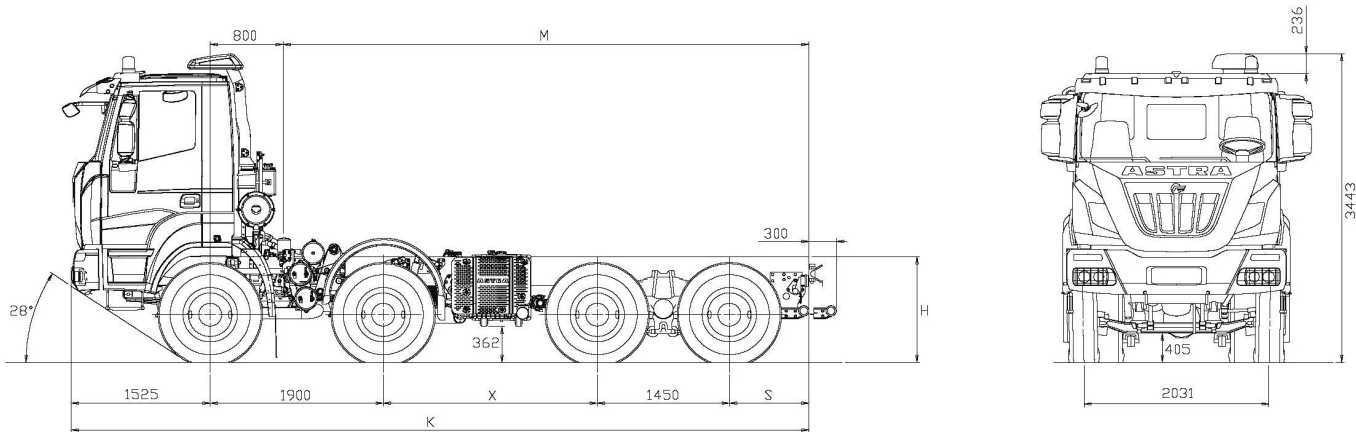

**chassis 8x4  
HD84.45**

**DIMENSIONS (MM)**

X	K	M max(*)	S	H		TURNING DIAMETER (wall to wall)
				unloaded	loaded	
4250	8425	6100	1200	1191	1131	19100
4500	8675	6350	1200	1191	1131	19900
4750	8925	6600	1200	1191	1131	20700
5000	9175	6850	1200	1191	1131	21500
6000	10475	8150	1500	1191	1131	24600

M max: indicative value to be confirmed by bodybuilder.  
Tyres I3 R22.5

**WEIGHTS (KG)**

X	Distribution net weight(*)			Max technical weight			
	Front axles	Rear axles	Net Weight	Front axles	Rear axles	Gross Vehicle Weight	Gross Combination Weight
4250	7260	4390	11650	16000 (1) 18000 (2)	32000 (2) 40000 (3) 42000 (4)	50000 (2) 58000 (3) 60000 (4)	121500
4500	7325	4350	11675				
4750	7390	4315	11705				
5000	7450	4285	11735				
6000	7620	4275	11895				

(\*) Net weight including driver with tanks filled to at least 90%, equipped with standard equipment according to the manufacturer's specifications and, if fitted, the mass of the bodywork, spare wheels and tool box.

- (1) With tyres on front axles 385/65R22.5 or 325/95R24 and reinforced springs (OPT).
- (2) With tyres 325/95R24 or max speed limited to 70km/h depending on pneus type and brand.
- (3) With rear narrow Kessler axles (OPT 400), tyres 325/95R24 and max speed limited to 70 km/h.
- (4) With rear narrow Kessler axles (OPT 400), tyres 325/95R24 and max speed limited to 40 km/h.

Higher speeds are allowed with load reductions subject to Astra technical office approval.



## ENGINES

**CURSOR 13** turbo intercooler electronic common rail with Hi-eSCR system. 6 in-line cylinders. Single block head, four valves per cylinder, light alloy pistons. Total displacement: 12.882 cm<sup>3</sup>. Bore for stroke: 135 x 150 mm. Water cooling. Dry air filter with safety cartridge.

Max.power(EEC)	450 KW (332 HP) @ 1900 rpm
Max.torque(EEC)	2200 Nm (224 kgm) @ 970 - 1440 rpm
Turbine	EVGT



## GEARBOX

Manual gearbox **ZF 16 S2225TO** Ecosplit 4 technology with servoshift, 16 synchronised forward speeds + 2 reverse.

**On request:** Automated **ZF AS-Tronic 16AS2630TO**.

Gearbox model	Rear axle ratio	Speed [kph] calculated at maximum power rpm																	
		Gears / Gear ratios																	
		1st	2nd	3rd	4th	5th	6th	7th	8th	9th	10th	11th	12th	13th	14th	15th	16th	rev. 1st	rev. 2nd
<b>16AS 2630 TO</b>		14.12	11.68	9.54	7.89	6.52	5.39	4.57	3.78	3.09	2.56	2.09	1.73	1.43	1.18	1	.83	13.07	10.81
	<b>5.01</b>	5.50	6.64	8.13	9.83	11.90	14.40	16.98	20.53	25.11	30.31	37.13	44.85	54.26	65.76	77.59	93.49*	5.94	7.18
<b>16S 2220 TO</b>		13.8	11.54	9.49	7.93	6.53	5.46	4.57	3.82	3.02	2.53	2.08	1.74	1.43	1.2	1.00	.84	12.92	10.8
	<b>5.01</b>	5.62	6.72	8.18	9.78	11.88	14.21	16.98	20.31	25.69	30.67	37.30	44.59	54.26	64.66	77.59	92.37*	6.01	7.18

(\*) Max limited speed 90 km/h. Other speeds available, subject to the Astra technical office approval.



## CLUTCH

Single dry plate, diameter 17". Pull type engagement with diaphragm spring. Hydro-pneumatic power steering engagement control, with driven disk wear recovery slave cylinder.



## AXLES

**FRONT:** Steering axle, hot moulding in high tensile steel. Wheel stud protection.  
**REAR:** Two drive axles in tandem. Double reduction: central with beveled pair, final in the wheel hubs by means of epicycloidal assembly. Torque distribution between the axles by means of a distributor fitted on the intermediate axle. Differential lockable from driver seat. Tandem assembled to the chassis by reaction rods with silentblock.

**On request:** Rear narrow Kessler axles (20+20 ton), including chassis reinforcement 10+6 mm (RBM 300.120 Nm).

Rear-axle ratio 1:4,229
Rear-axle ratio 1:5,009
Rear-axle ratio 1:5,558
Rear-axle ratio 1:6,095
Rear-axle ratio 1:6,588



## SUSPENSIONS

**FRONT:** Parabolic springs, n° 3 leaves 26x90 mm, hydraulic shock absorbers. Standard stabilizer bar on 1st axle.

**On request:** Stabilizer bar on 2nd axle. Reinforced parabolic springs, n° 4 leaves 26x90 mm.

**REAR:** Parabolic springs, swiveling on central pin: n° 4 leaves 40x100mm, torque bars and stiffening brackets. Standard stabilizer bar on 4th axle.

**On request:** Stabilizer bar on 3rd axle. Extra-reinforced conventional springs, n° 10 leaves 25x100 mm.



## CHASSIS

Special steel with high tensile strength limit, two flat and parallel side members (width 820 mm.), C section (320x90x10mm), cross members bolted to the frame. R.B.M. (Rail Bending Moment): 202.020 Nm (20.593 Kg.m.). Steel front bumpers with headlamp protection grids, front maneuvering hook, rear underrun bar, rubber mud-guard 2nd axle, steel fuel tank capacity 300 litres.



## ELECTRICAL SYSTEM

Voltage: 24 V; Alternator generator 90 A - 28 V (2520 W).

Accumulators: 2 in series, 170 Ah.

Starter motor 24 V 5,5 kW.

Mechanically controlled electrical circuit breaker.



## TYRES

**FRONT:** 13R22,5 156/150 G Single tubeless

**REAR:** 13R22,5 156/150 G Twin tubeless

Spare wheel on the chassis.

Other Possible combinations:

315/80 R22,5 156/150K

385/65 R22,5 160J (\*) + 315/80 R22,5 156/150K

325/95 R24 162/160K (\*\*)(\*\*)

(\*) Mandatory with 9 ton front axle load.

(\*\*) Mandatory with rear Kessler axles (opt 400).

Other tyres available, subject to Astra technical office approval.



## BRAKES

Front and rear "duo-duplex" self-adjusting wedge type brakes with automatic play take-up.

Total net braking surface 12.368 cm<sup>2</sup>. ABS + EBL.

**Service brake:** Pedal controlled air brake, acting on all wheels.

Solo vehicles, two independent circuits, one for 1st and 2nd axle, one for 3rd and 4th axle.

Towing vehicles, three independent circuits, one for 1st and 2nd axle, one for 3rd and 4th axle and another for the trailer.

**Emergency brake:** Incorporated in service brake.

**Parking brake:** Manual spring-type mechanical with pneumatic control acting on 3rd and 4th axle wheels.

**On request:**

Hydraulic intarder.

OFF/ROAD button for excluding ABS for speed 15 kph.



## STEERING

ZF 8099 quadrilateral power steering on front axle wheels with variable ratio

1:22.2/1:26.2 with auxiliary cylinder. Circuit with main hydraulic pump on engine and emergency pump on gearbox. Steering rods with self-lubricating joints. Height and inclination pneumatic adjustable steering column.



## CAB

White cab built in galvanized pressed steel with hydraulic tilting up to 60°. Cab suspension with 4 helicoidal springs with coaxial shock absorbers and integrated dampers, antiroll bar and end-of-stroke pads. Tinted electric door windows.

Internal panels completely washable and fireproof. Rapid pneumatic connection for cab cleaning. 4-speed ventilation and heating system with air recirculation system.

Air suspended 3-way adjustable driver seat with seat belts. Mechanical passenger seat with seat belts.